

**GigaDevice Semiconductor Inc.**

**GD32403Z-EVAL  
User Manual**

## Table of Contents

<b>Table of Contents</b> .....	<b>1</b>
<b>List of Tables</b> .....	<b>3</b>
<b>1 Summary</b> .....	<b>4</b>
<b>2 Function Pin Assign</b> .....	<b>4</b>
<b>3 Getting started</b> .....	<b>6</b>
<b>4 Hardware layout overview</b> .....	<b>7</b>
4.1 Power .....	7
4.2 Boot .....	7
4.3 LED.....	8
4.4 KEY .....	8
4.5 USART .....	9
4.6 ADC.....	9
4.7 DAC.....	9
4.8 I2S .....	10
4.9 I2C.....	10
4.10 SPI.....	11
4.11 CAN.....	11
4.12 SDIO.....	12
4.13 NAND .....	12
4.14 LCD .....	13
4.15 USBFS .....	14
4.16 Extension.....	14
4.17 GD-Link .....	15
<b>5 Routine use guide</b> .....	<b>15</b>
5.1 GPIO_Runing_Led.....	15
5.2 GPIO_Keyboard_Polling_mode.....	16
5.3 GPIO_KeyBoard_Interrupt_mode.....	16
5.4 USART_Printf.....	17
5.5 USART_Echo_Interrupt_mode .....	17
5.6 USART_DMA .....	18
5.7 ADC_Temperature_Vrefint.....	19
5.8 ADC0_ADC1_Follow_up_mode .....	19
5.9 ADC0_ADC1_Regular_Parallel_mode .....	20
5.10 DAC_Output_Voltage_Value.....	21
5.11 I2C_EEPROM .....	22
5.12 SPI_SPI_Flash.....	23
5.13 I2S_Audio_Player .....	24
5.14 EXMC_NandFlash .....	25
5.15 EXMC_TouchScreen.....	26
5.16 SDIO_SDCardTest.....	27
5.17 CAN_Network.....	28

---

5.18	RCU_Clock_Out.....	28
5.19	CTC_Calibration.....	29
5.20	PMU_sleep_wakeup .....	30
5.21	RTC_Calendar .....	30
5.22	TIMER_Breath_LED .....	31
5.23	USB_Device .....	31
5.24	USB_Host.....	34
<b>6</b>	<b>Revision history.....</b>	<b>36</b>

## List of Tables

<i>Table 1 Function pin assign</i> .....	4
<i>Table 2 Revision history</i> .....	36

## 1 Summary

GD32403Z-EVAL uses GD32F403ZET6 as the main controller. It uses Mini USB interface or DC-005 connector to supply 5V power. SWD, Reset, Boot, User button key, LED, CAN, I2C, I2S, USART, RTC, LCD, SPI, ADC, DAC, EXMC, CTC, SDIO, USBFS, GD-Link and Extension Pins are also included. For more details please refer to GD32403Z-EVAL-V1.0 schematic.

## 2 Function Pin Assign

**Table 1 Function pin assign**

Function	Pin	Description
LED	PF0	LED2
	PF1	LED3
	PF2	LED4
	PF3	LED5
RESET		K1-Reset
KEY	PA0	K2-Wakeup
	PC13	K3-Tamper
	PF5	K4-User key1
	PF4	K5-User key2
USART0	PA9	USART0_TX
	PA10	USART0_RX
ADC	PC3	ADC012_IN13
DAC	PA4	DAC_OUT0
	PA5	DAC_OUT1
I2C	PB6	I2C0_SCL
	PB7	I2C0_SDA
SPI	PA5	SPI0_SCK
	PA6	SPI0_MISO
	PA7	SPI0_MOSI
	PE3	SPI0_CS
I2S	PA4	MSEL
	PA5	MCLK
	PA7	MDIN
	PB12	I2S_WS
	PB13	I2S_CK
	PB15	I2S_DIN
CAN	PC6	I2S_MCK
	PD0	CAN0_RX
	PD1	CAN0_TX

SDIO	PD2	SDIO_CMD
	PC12	SDIO_CLK
	PC8	SDIO_DAT0
	PC9	SDIO_DAT1
	PC10	SDIO_DAT2
	PC11	SDIO_DAT3
NAND Flash	PD14	EXMC_D0
	PD15	EXMC_D1
	PD0	EXMC_D2
	PD1	EXMC_D3
	PE7	EXMC_D4
	PE8	EXMC_D5
	PE9	EXMC_D6
	PE10	EXMC_D7
	PD11	EXMC_A16
	PD12	EXMC_A17
	PD4	EXMC_NOE
	PD5	EXMC_NWE
	PD6	EXMC_NWAIT
	PD7	EXMC_NCE1
LCD	PD14	EXMC_D0
	PD15	EXMC_D1
	PD0	EXMC_D2
	PD1	EXMC_D3
	PE7	EXMC_D4
	PE8	EXMC_D5
	PE9	EXMC_D6
	PE10	EXMC_D7
	PE11	EXMC_D8
	PE12	EXMC_D9
	PE13	EXMC_D10
	PE14	EXMC_D11
	PE15	EXMC_D12
	PD8	EXMC_D13
	PD9	EXMC_D14
	PD10	EXMC_D15
	PE2	EXMC_A23
	PD4	EXMC_NOE
	PD5	EXMC_NWE
	PG9	EXMC_NE1
USBFS	PA9	USB_VBUS
	PA11	USB_DM

	PA12	USB_DP
	PA10	USB_ID

### 3 Getting started

The EVAL board uses Mini USB connector or DC-005 connector to get power DC +5V, which is the hardware system normal work voltage. A J-Link tool or GD-Link on board is necessary in order to download and debug programs. Select the correct boot mode and then power on, the LED1 will turn on, which indicates that the power supply is OK.

There are Keil version and IAR version of all projects. Keil version of the projects are created based on Keil MDK-ARM 4.74 uVision4. IAR version of the projects are created based on IAR Embedded Workbench for ARM 7.40.2. During use, the following points should be noted:

1. If you use Keil uVision4 to open the project, install the GD32F4xx\_Addon.1.0.2.exe to load the associated files.
2. If you use Keil uVision5 to open the project, there are two ways to solve the "Device Missing (s)" problem. One is to install GigaDevice.GD32F4xx\_DFP.1.0.2.pack. In Project menu, select the Manage sub menu, click on the "Version Migrate 5 Format..." menu, the Keil uVision4 project will be converted to Keil uVision5 project. Then add "C:\Keil\_v5\ARM\Pack\ARM\CMSIS\4.2.0\CMSIS\Include" to C/C++ in Option for Target. The other is to install Addon directly. Select the installation directory of Keil uVision5 software, such as C:\Keil\_v5, in Destination Folder of Folder Selection. Select the corresponding device in Device of Option for Target and add "C:\Keil\_v5\ARM\Pack\ARM\CMSIS\4.2.0\CMSIS\Include" to C/C++ in Option for Target.
3. If you use IAR to open the project, install IAR\_GD32F4xx\_Addon.1.0.0.exe to load the associated files.

## 4 Hardware layout overview

### 4.1 Power

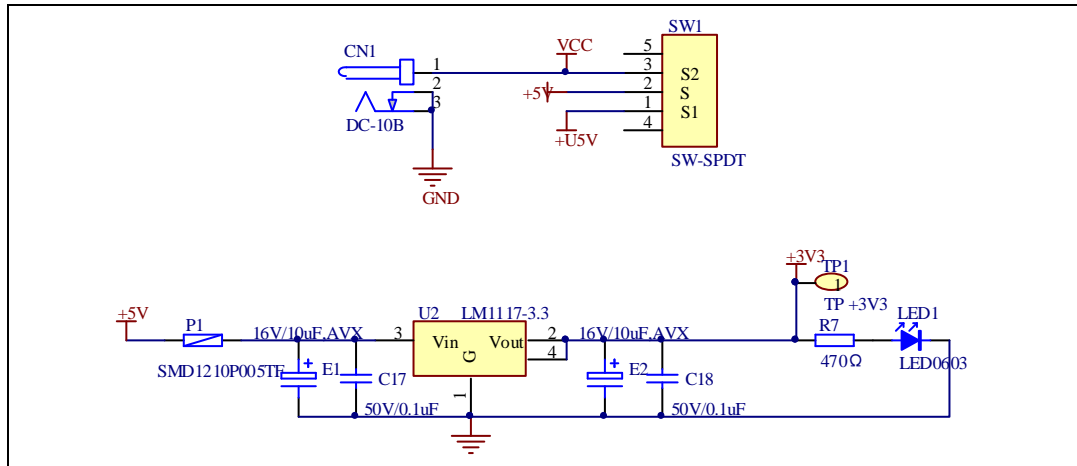

### 4.2 Boot

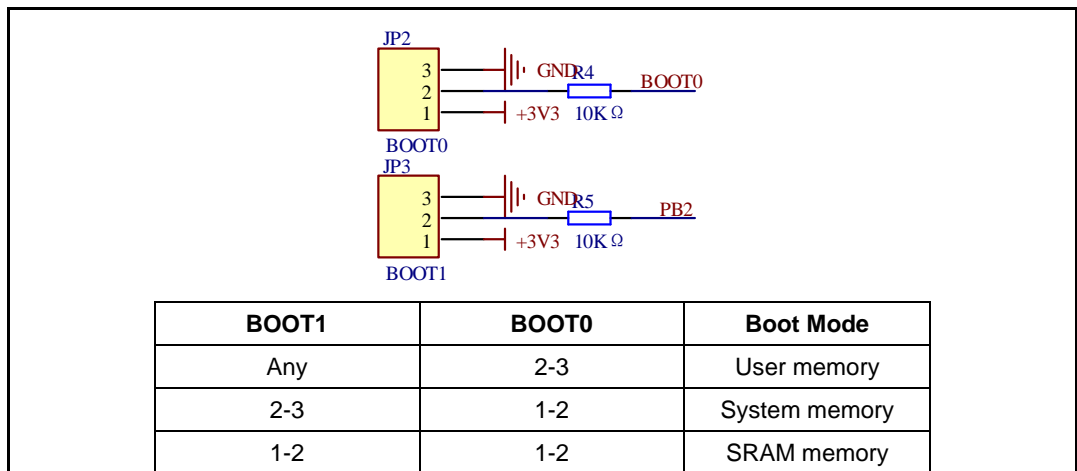



### 4.3 LED

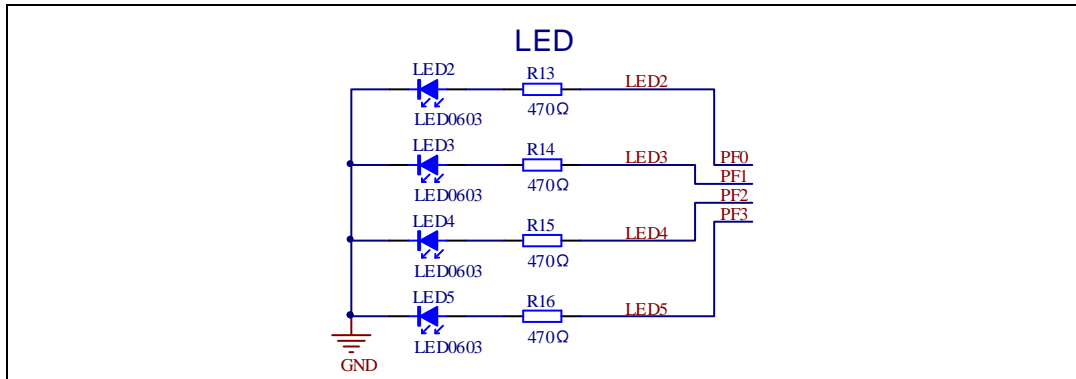

### 4.4 KEY

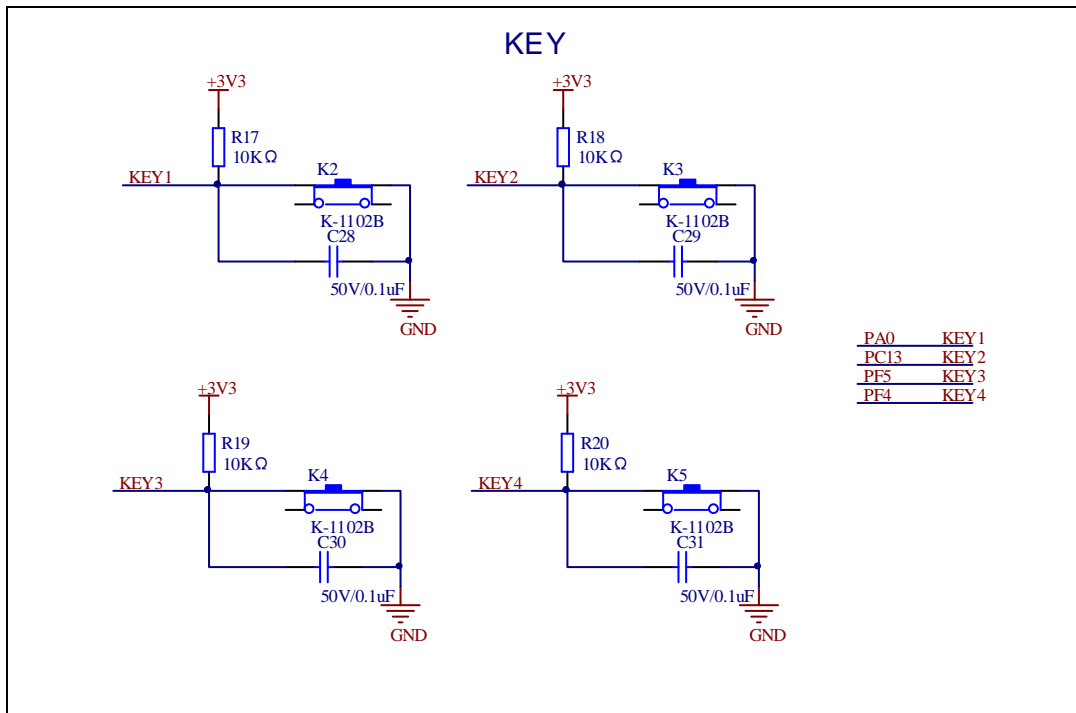

## 4.5 USART

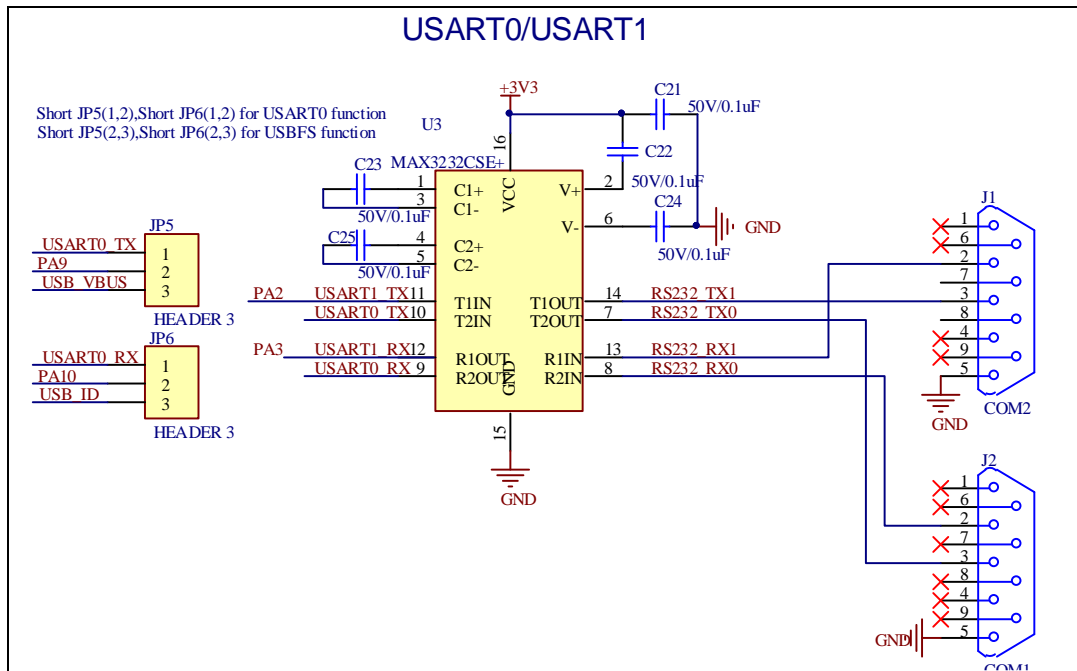

## 4.6 ADC

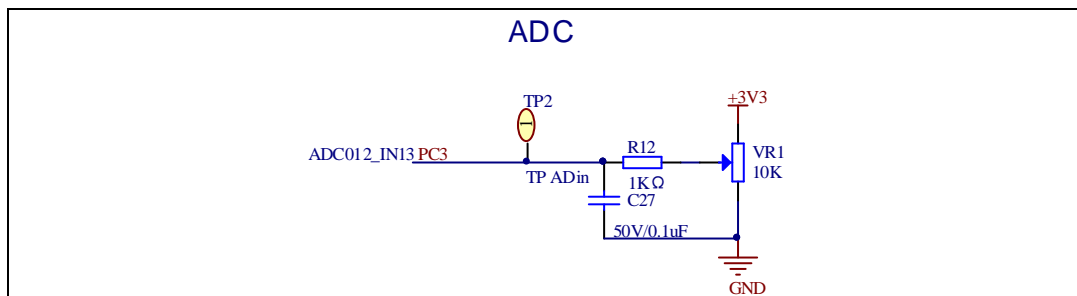

## 4.7 DAC

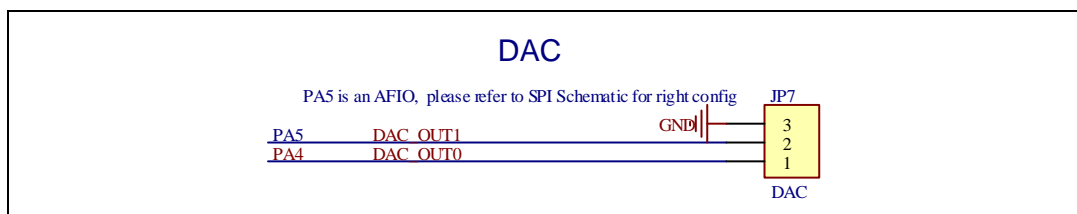

## 4.8 I2S

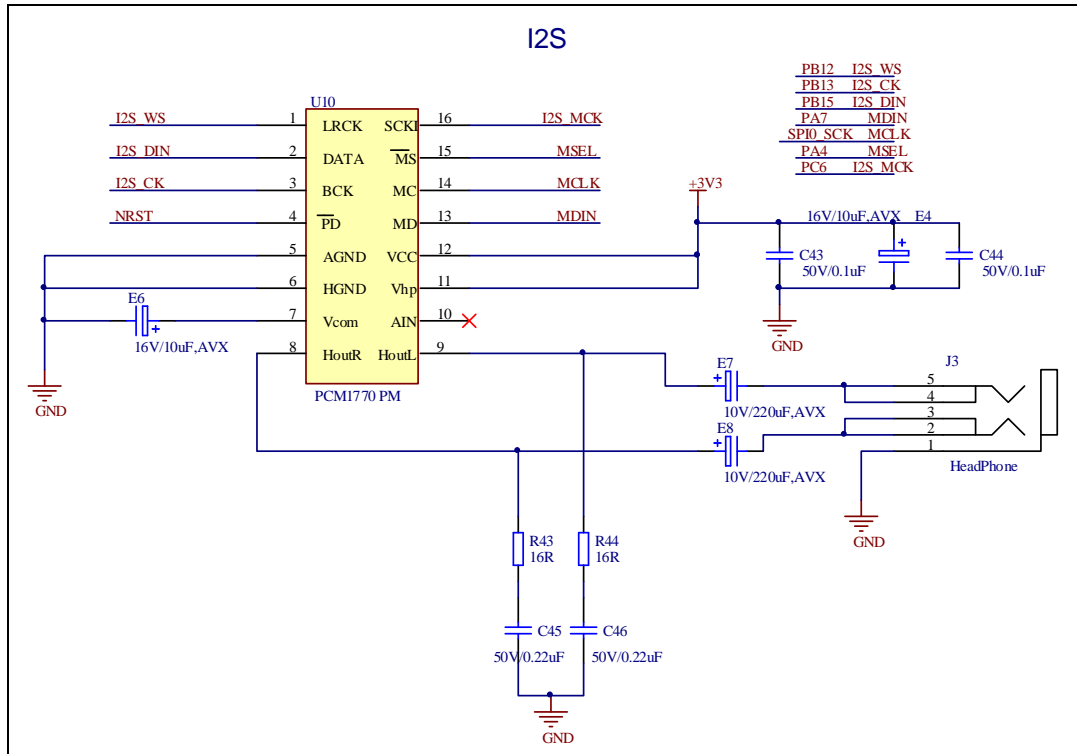

## 4.9 I2C

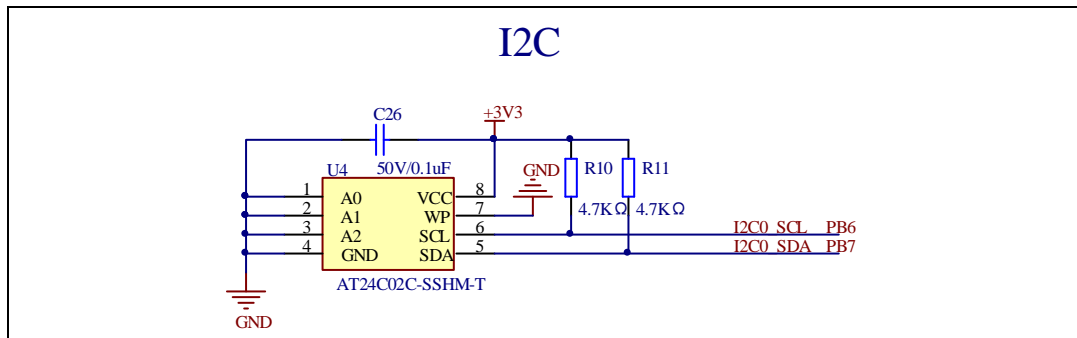

## 4.10 SPI

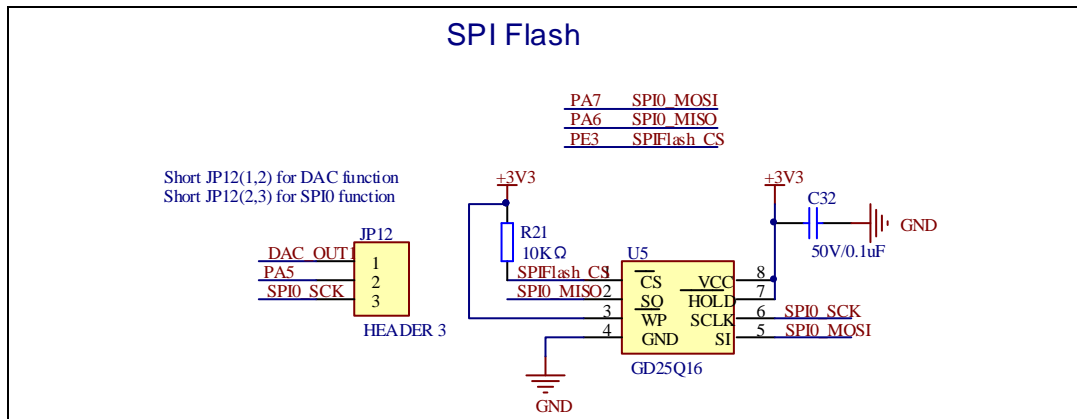

## 4.11 CAN

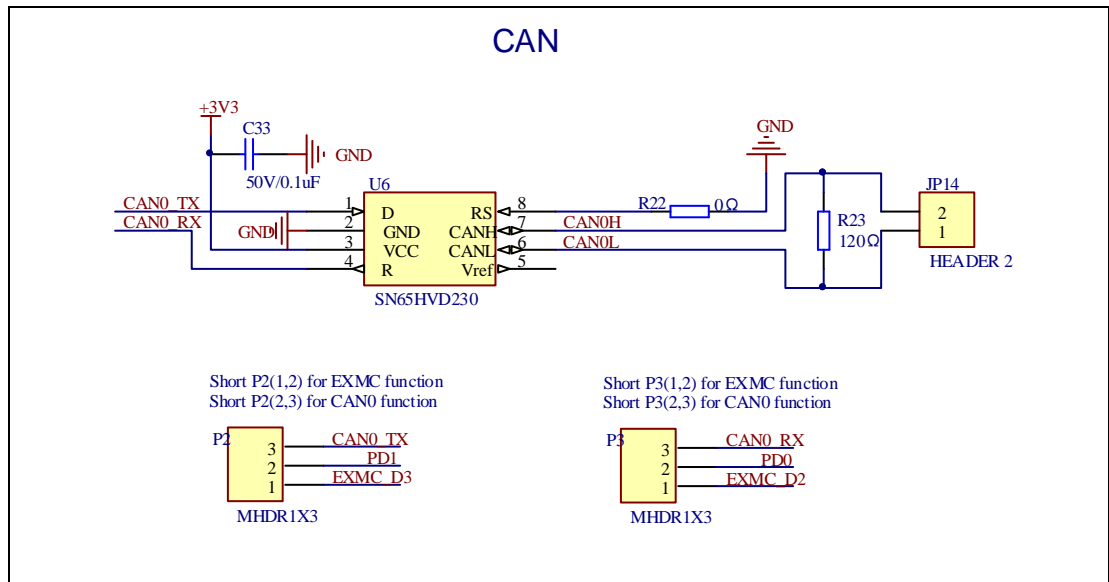

## 4.12 SDIO

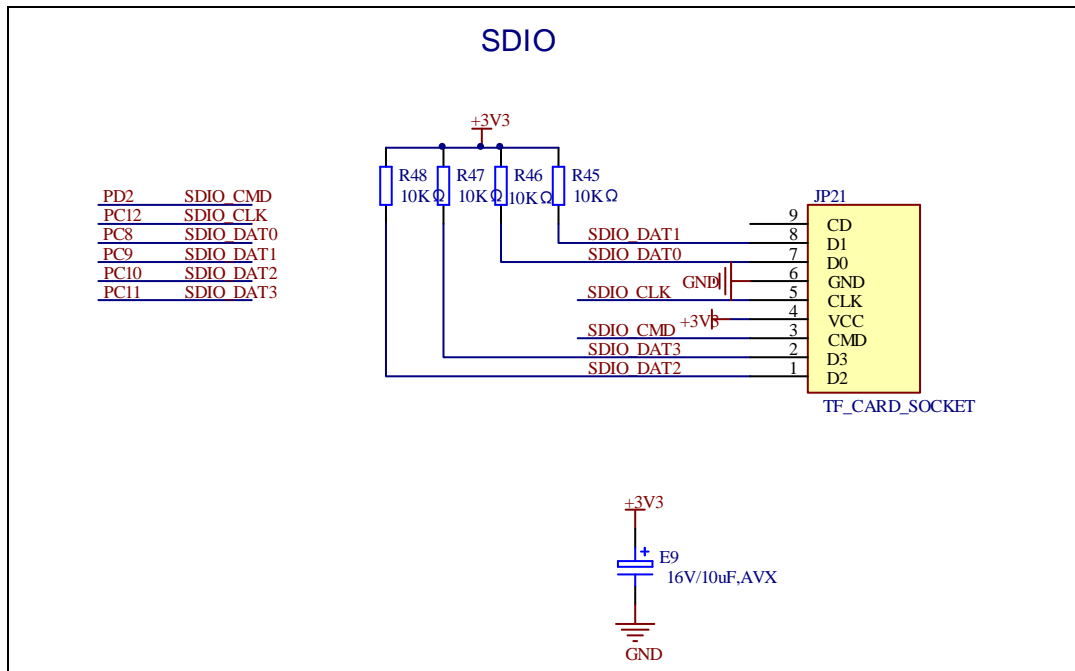

## 4.13 NAND

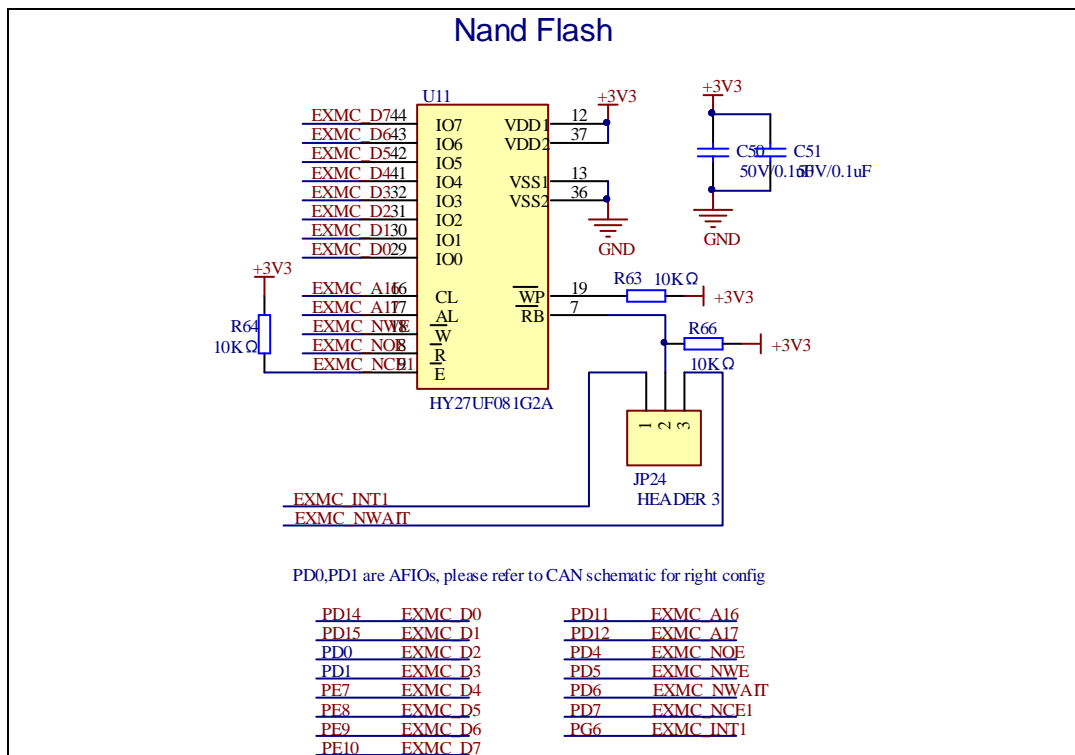

## 4.14 LCD

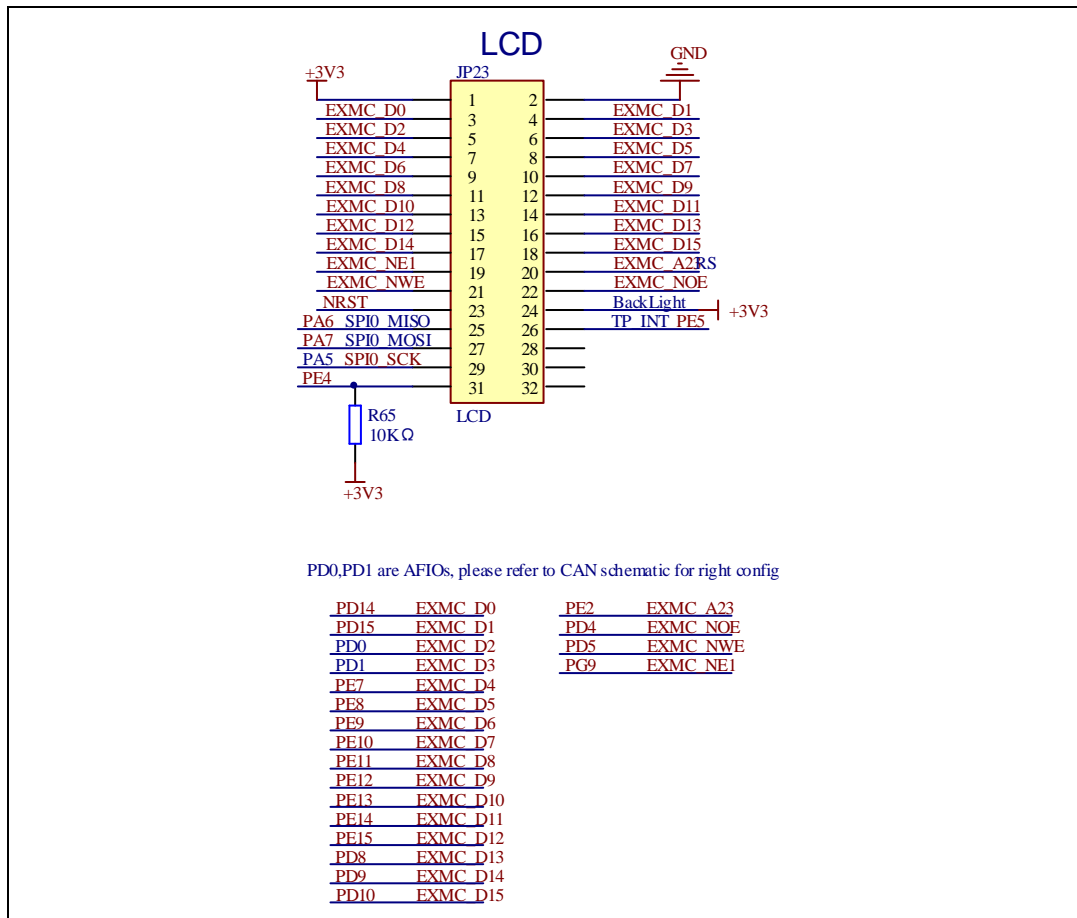

## 4.15 USBFS

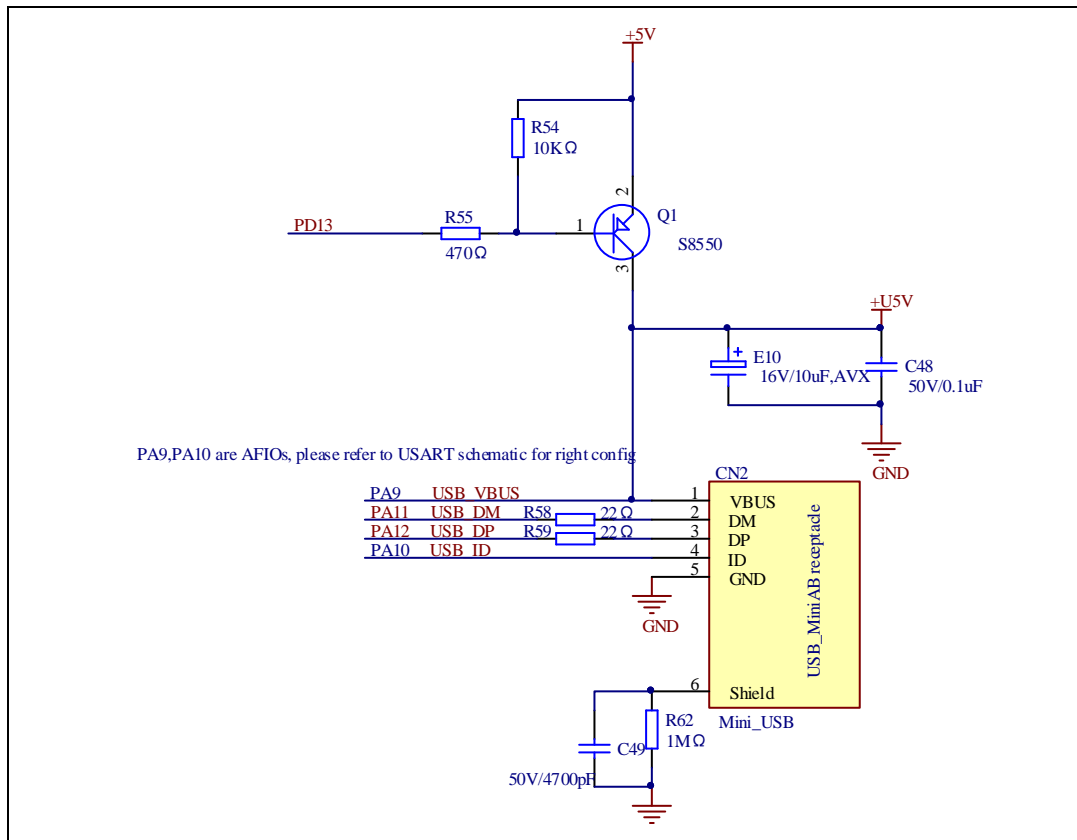

## 4.16 Extension

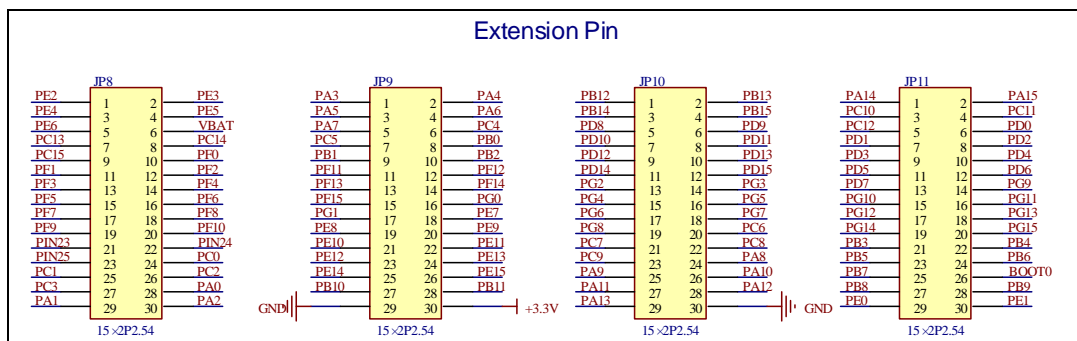

## 4.17 GD-Link

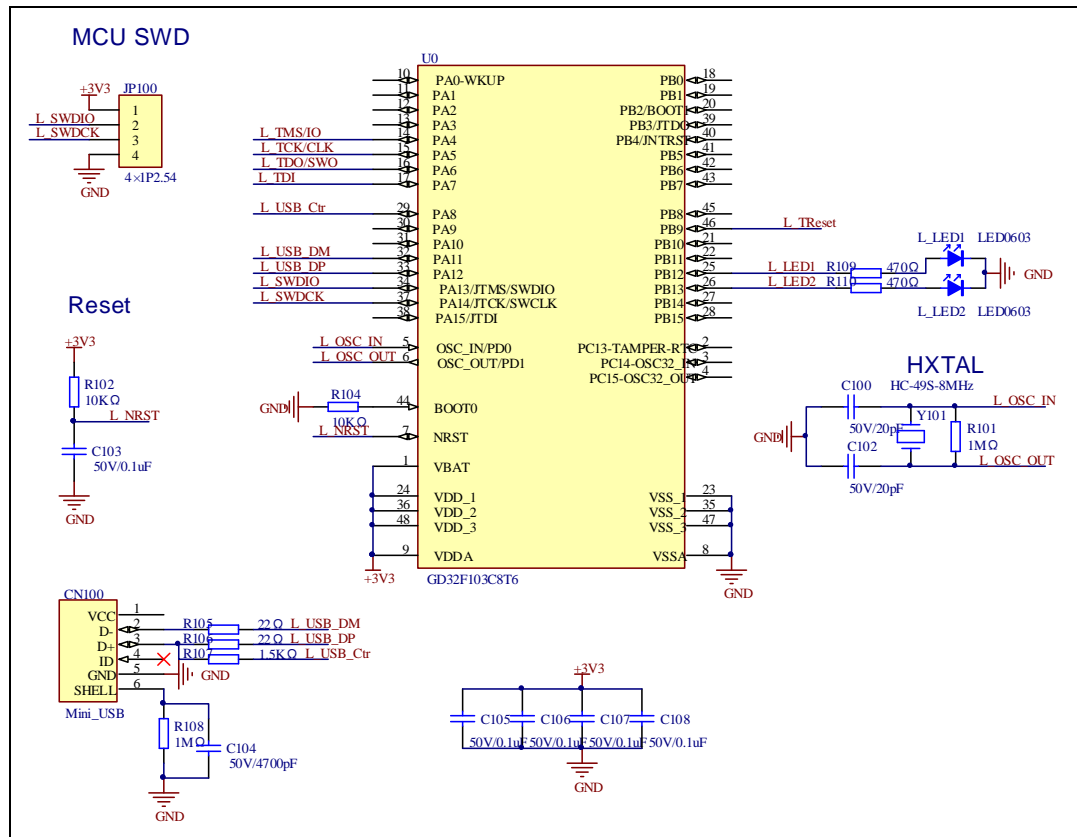

## 5 Routine use guide

### 5.1 GPIO\_Runing\_Led

#### 5.1.1 DEMO Purpose

This demo includes the following functions of GD32 MCU:

- Learn to use GPIO control the LED
- Learn to use SysTick to generate 1ms delay

GD32403Z-EVAL board has four LEDs. The LED2, LED3, LED4 and LED5 are controlled by GPIO. This demo will show how to light the LEDs.

#### 5.1.2 DEMO Running Result

Download the program <01\_GPIO\_Runing\_Led> to the EVAL board, LED2, LED3, LED4



will turn on in sequence with interval of 200ms, and turn off together, 200ms later, repeat the process.

## 5.2 GPIO\_Keyboard\_Polling\_mode

### 5.2.1 DEMO Purpose

This demo includes the following functions of GD32 MCU:

- Learn to use GPIO control the LED and the KEY
- Learn to use SysTick to generate 1ms delay

GD32403Z-EVAL board has five keys and four LEDs. The five keys are Reset key, Tamper key, Wakeup key, User1 key and User2 key. The LED2, LED3, LED4 and LED5 are controlled by GPIO.

This demo will show how to use the Tamper key to control the LED2. When press down the Tamper Key, it will check the input value of the IO port. If the value is 0 and will wait for 50ms. Check the input value of the IO port again. If the value still is 0, it indicates that the button is pressed successfully and toggle LED2.

### 5.2.2 DEMO Running Result

Download the program <02\_GPIO\_KeyBoard\_Polling\_mode> to the EVAL board, press down the Tamper Key, LED2 will be turned on. Press down the Tamper Key again, LED2 will be turned off.

## 5.3 GPIO\_Keyboard\_Interrupt\_mode

### 5.3.1 DEMO Purpose

This demo includes the following functions of GD32 MCU:

- Learn to use GPIO control the LED and the KEY
- Learn to use EXTI to generate external interrupt

GD32403Z-EVAL board has five keys and four LEDs. The five keys are Reset key, Tamper key, Wakeup key, User1 key and User2 key. The LED2, LED3, LED4 and LED5 are controlled by GPIO.

This demo will show how to use the EXTI interrupt line to control the LED2. When press down the Tamper Key, it will produce an interrupt. In the interrupt service function, the demo will toggle LED2.

## 5.3.2 DEMO Running Result

Download the program <03\_GPIO\_KeyBoard\_Interrupt\_mode> to the EVAL board, Press down the Tamper Key, LED2 will be turned on. Press down the Tamper Key again, LED2 will be turned off.

## 5.4 USART\_Printf

### 5.4.1 DEMO Purpose

This demo includes the following functions of GD32 MCU:

- Learn to use GPIO control the LED
- Learn to retarget the C library printf function to the USART

### 5.4.2 DEMO Running Result

Download the program < 04\_USART\_Printf > to the EVAL board, jump the JP5 to USART with the jumper cap and connect serial cable to EVAL\_COM1. This implementation outputs “USART printf example: please press the Tamper key” on the HyperTerminal using EVAL\_COM1. Press the Tamper key, serial port will output “USART printf example”. The output information via the serial port is as following.

```
USART printf example: please press the Tamper key
USART printf example
```

## 5.5 USART\_Echo\_Interrupt\_mode

### 5.5.1 DEMO Purpose

This demo includes the following functions of GD32 MCU:

- Learn to use the USART transmit and receive interrupts to communicate with the serial terminal tool

### 5.5.2 DEMO Running Result

Download the program < 05\_USART\_Echo\_Interrupt\_mode > to the EVAL board, jump the JP5 and JP6 to USART with the jumper cap and connect serial cable to EVAL\_COM1.

Firstly, all the LEDs are turned on and off for test. Then, the EVAL\_COM1 sends the tx\_buffer array (from 0x00 to 0xFF) to the serial terminal tool supporting hex format communication and waits for receiving data of BUFFER\_SIZE bytes from the serial terminal. The data MCU have received is stored in the rx\_buffer array. After that, compare tx\_buffer with rx\_buffer. If tx\_buffer is same with rx\_buffer, LED2, LED3, LED4, LED5 flash by turns. Otherwise, LED2, LED3, LED4, LED5 toggle together.

The output information via the serial port is as following.

```
00 01 02 03 04 05 06 07 08 09 0A 0B 0C 0D 0E 0F 10 11 12 13 14 15 16 17 18 19 1A 1B
1C 1D 1E 1F 20 21 22 23 24 25 26 27 28 29 2A 2B 2C 2D 2E 2F 30 31 32 33 34 35 36 37
38 39 3A 3B 3C 3D 3E 3F 40 41 42 43 44 45 46 47 48 49 4A 4B 4C 4D 4E 4F 50 51 52 53
54 55 56 57 58 59 5A 5B 5C 5D 5E 5F 60 61 62 63 64 65 66 67 68 69 6A 6B 6C 6D 6E 6F
70 71 72 73 74 75 76 77 78 79 7A 7B 7C 7D 7E 7F 80 81 82 83 84 85 86 87 88 89 8A 8B
8C 8D 8E 8F 90 91 92 93 94 95 96 97 98 99 9A 9B 9C 9D 9E 9F A0 A1 A2 A3 A4 A5 A6 A7
A8 A9 AA AB AC AD AE AF B0 B1 B2 B3 B4 B5 B6 B7 B8 B9 BA BB BC BD BE BF C0 C1 C2 C3
C4 C5 C6 C7 C8 C9 CA CB CC CD CE CF D0 D1 D2 D3 D4 D5 D6 D7 D8 D9 DA DB DC DD DE DF
E0 E1 E2 E3 E4 E5 E6 E7 E8 E9 EA EB EC ED EE EF F0 F1 F2 F3 F4 F5 F6 F7 F8 F9 FA FB
FC FD FE FF
```

## 5.6 USART\_DMA

### 5.6.1 DEMO Purpose

This demo includes the following functions of GD32 MCU:

- Learn to use the USART transmit and receive data using DMA

### 5.6.2 DEMO Running Result

Download the program < 06\_USART\_DMA > to the EVAL board, jump the JP5 and JP6 to USART with the jumper cap and connect serial cable to EVAL\_COM1. Firstly, all the LEDs are turned on and off for test. Then, the EVAL\_COM1 sends the tx\_buffer array (from 0x00 to 0xFF) to the serial terminal tool supporting hex format communication and waits for receiving data of same bytes as tx\_buffer from the serial terminal. The data MCU have received is stored in the rx\_buffer array. After that, compare tx\_buffer with rx\_buffer. If tx\_buffer is same with rx\_buffer, LED2, LED3, LED4, LED5 flash by turns. Otherwise, LED2, LED3, LED4, LED5 toggle together.

```
00 01 02 03 04 05 06 07 08 09 0A 0B 0C 0D 0E 0F 10 11 12 13 14 15 16 17 18 19 1A 1B
1C 1D 1E 1F 20 21 22 23 24 25 26 27 28 29 2A 2B 2C 2D 2E 2F 30 31 32 33 34 35 36 37
38 39 3A 3B 3C 3D 3E 3F 40 41 42 43 44 45 46 47 48 49 4A 4B 4C 4D 4E 4F 50 51 52 53
54 55 56 57 58 59 5A 5B 5C 5D 5E 5F 60 61 62 63 64 65 66 67 68 69 6A 6B 6C 6D 6E 6F
70 71 72 73 74 75 76 77 78 79 7A 7B 7C 7D 7E 7F 80 81 82 83 84 85 86 87 88 89 8A 8B
8C 8D 8E 8F 90 91 92 93 94 95 96 97 98 99 9A 9B 9C 9D 9E 9F A0 A1 A2 A3 A4 A5 A6 A7
A8 A9 AA AB AC AD AE AF B0 B1 B2 B3 B4 B5 B6 B7 B8 B9 BA BB BC BD BE BF C0 C1 C2 C3
C4 C5 C6 C7 C8 C9 CA CB CC CD CE CF D0 D1 D2 D3 D4 D5 D6 D7 D8 D9 DA DB DC DD DE DF
E0 E1 E2 E3 E4 E5 E6 E7 E8 E9 EA EB EC ED EE EF F0 F1 F2 F3 F4 F5 F6 F7 F8 F9 FA FB
FC FD FE FF
```

## 5.7 ADC\_Temperature\_Vrefint

### 5.7.1 DEMO Purpose

This demo includes the following functions of GD32 MCU:

- Learn to use the ADC to convert analog signal to digital data
- Learn to get the value of inner channel 16(temperature sensor channel) and channel 17 (VREFINT channel)

### 5.7.2 DEMO Running Result

Jump the JP5 and JP6 to USART with the jumper cap, and then download the program <07\_ADC\_Temperature\_Vrefint> to the GD32403Z-EVAL-V1.0 board. Connect serial cable to EVAL\_COM1, open the HyperTerminal.

When the program is running, HyperTerminal display the value of temperature and internal voltage reference ( $V_{REFINT}$ ).

Notice: because there is an offset, when inner temperature sensor is used to detect accurate temperature, an external temperature sensor part should be used to calibrate the offset error.

```
the temperature data is 31 degrees Celsius  
the reference voltage data is 1.205V
```

```
the temperature data is 31 degrees Celsius  
the reference voltage data is 1.206V
```

```
the temperature data is 31 degrees Celsius  
the reference voltage data is 1.206V
```

```
the temperature data is 31 degrees Celsius  
the reference voltage data is 1.206V
```

```
the temperature data is 31 degrees Celsius  
the reference voltage data is 1.205V
```

```
the temperature data is 31 degrees Celsius  
the reference voltage data is 1.205V
```

## 5.8 ADC0\_ADC1\_Follow\_up\_mode

### 5.8.1 DEMO Purpose

This demo includes the following functions of GD32 MCU:

- Learn to use the ADC to convert analog signal to digital data
- Learn to use ADC0 and ADC1 follow-up mode

## 5.8.2 DEMO Running Result

Jump the JP5 and JP6 to USART with the jumper cap, and then download the program <08\_ADC0\_ADC1\_Follow\_up\_mode> to the GD32403Z-EVAL-V1.0 board. Connect serial cable to EVAL\_COM1, open the HyperTerminal. PC3 and PC5 pin voltage access by external voltage.

TIMER0\_CH0 is the trigger source of ADC0 and ADC1. When the rising edge of TIMER0\_CH0 coming, ADC0 starts immediately and ADC1 starts after a delay of several ADC clock cycles. The values of ADC0 and ADC1 are transmitted to array `adc_value[0]` and `adc_value[1]` by DMA.

When the first rising edge of TIMER0\_CH0 coming, the value of the ADC0 conversion of PC3 pin is stored into the low half word of `adc_value[0]`, and after a delay of several ADC clock cycles the value of the ADC1 conversion of PC5 pin is stored into the high half word of `adc_value[0]`. When the second rising edge of TIMER0\_CH0 coming, the value of the ADC0 conversion of PC5 pin is stored into the low half word of `adc_value[1]`, and after a delay of several ADC clock cycles the value of the ADC1 conversion of PC3 pin is stored into the high half word of `adc_value[1]`.

When the program is running, HyperTerminal display the regular value of ADC0 and ADC1 by `adc_value[0]` and `adc_value[1]`.

```
the data adc_value[0] is 00000982  
the data adc_value[1] is 09C00000
```

```
the data adc_value[0] is 00000988  
the data adc_value[1] is 098D0000
```

```
the data adc_value[0] is 00000988  
the data adc_value[1] is 098D0000
```

```
the data adc_value[0] is 00000983  
the data adc_value[1] is 098F0000
```

```
the data adc_value[0] is 00000987  
the data adc_value[1] is 098F0000
```

```
the data adc_value[0] is 00000985  
the data adc_value[1] is 098E0000
```

## 5.9 ADC0\_ADC1\_Regular\_Parallel\_mode

### 5.9.1 DEMO Purpose

This demo includes the following functions of GD32 MCU:

- Learn to use the ADC to convert analog signal to digital data
- Learn to use ADC0 and ADC1 regular parallel mode

## 5.9.2 DEMO Running Result

Jump the JP5 and JP6 to USART with the jumper cap, and then download the program <09\_ADC0\_ADC1\_Regular\_Parallel\_mode> to the GD32403Z-EVAL-V1.0 board. Connect serial cable to EVAL\_COM1, open the HyperTerminal. PC3 and PC5 pin connect to external voltage input.

TIMER0\_CH0 is the trigger source of ADC0 and ADC1. When the rising edge of TIMER0\_CH0 coming, ADC0 and ADC1 convert the regular channel group parallelly. The values of ADC0 and ADC1 are transmitted to array `adc_value[0]` and `adc_value[1]` by DMA.

When the first rising edge of TIMER0\_CH0 coming, the value of the ADC0 conversion of PC3 pin is stored into the low half word of `adc_value[0]`, the value of the ADC1 conversion of PC5 pin is stored into the high half word of `adc_value[0]`. When the second rising edge of TIMER0\_CH0 coming, the value of the ADC0 conversion of PC5 pin is stored into the low half word of `adc_value[1]`, the value of the ADC1 conversion of PC3 pin is stored into the high half word of `adc_value[1]`.

When the program is running, HyperTerminal displays the regular value of ADC0 and ADC1 stored in `adc_value[0]` and `adc_value[1]`.

```
the data adc_value[0] is 000009BB  
the data adc_value[1] is 09BB0000
```

```
the data adc_value[0] is 000009BB  
the data adc_value[1] is 09BB0000
```

```
the data adc_value[0] is 000009B9  
the data adc_value[1] is 09BB0000
```

```
the data adc_value[0] is 000009BB  
the data adc_value[1] is 09BA0000
```

```
the data adc_value[0] is 000009BA  
the data adc_value[1] is 09BA0000
```

## 5.10 DAC\_Output\_Voltage\_Value

### 5.10.1 DEMO Purpose

This demo includes the following functions of GD32 MCU:

- Learn to use DAC to output voltage on DAC0 output

### 5.10.2 DEMO Running Result

Download the program <10\_DAC\_Output\_Voltage\_Value> to the EVAL board and run, all the LEDs will turn on and turn off for test. The digital value is 0x7FF0, its converted analog voltage should be 1.65V ( $V_{REF}/2$ ), using the voltmeter to measure PA4 or DA1

on JP7, its value is 1.65V.

## 5.11 I2C\_EEPROM

### 5.11.1 DEMO Purpose

This demo includes the following functions of GD32 MCU:

- Learn to use the master transmitting mode of I2C module
- Learn to use the master receiving mode of I2C module
- Learn to read and write the EEPROM with I2C interface

### 5.11.2 DEMO Running Result

Jump the JP5 to USART with the jumper cap, and download the program <11\_I2C\_EEPROM> to the EVAL board and run. Connect serial cable to COM1, and open the HyperTerminal to show the print message.

Firstly, the data of 256 bytes will be written to the EEPROM from the address 0x00 and printed by the serial port. Then, reading the EEPROM from address 0x00 for 256 bytes and the result will be printed. Finally, compare the data that were written to the EEPROM and the data that were read from the EEPROM. If they are the same, the serial port will output "I2C-AT24C02 test passed!" and the four LEDs lights flashing, otherwise the serial port will output "Err: data read and write aren't matching." and all the four LEDs light.

The output information via the serial port is as following.

```
I2C-24C02 configured...
The I2C0 is hardware interface
The speed is 400000
AT24C02 writing...
0x00 0x01 0x02 0x03 0x04 0x05 0x06 0x07 0x08 0x09 0x0A 0x0B 0x0C 0x0D 0x0E 0x0F
0x10 0x11 0x12 0x13 0x14 0x15 0x16 0x17 0x18 0x19 0x1A 0x1B 0x1C 0x1D 0x1E 0x1F
0x20 0x21 0x22 0x23 0x24 0x25 0x26 0x27 0x28 0x29 0x2A 0x2B 0x2C 0x2D 0x2E 0x2F
0x30 0x31 0x32 0x33 0x34 0x35 0x36 0x37 0x38 0x39 0x3A 0x3B 0x3C 0x3D 0x3E 0x3F
0x40 0x41 0x42 0x43 0x44 0x45 0x46 0x47 0x48 0x49 0x4A 0x4B 0x4C 0x4D 0x4E 0x4F
0x50 0x51 0x52 0x53 0x54 0x55 0x56 0x57 0x58 0x59 0x5A 0x5B 0x5C 0x5D 0x5E 0x5F
0x60 0x61 0x62 0x63 0x64 0x65 0x66 0x67 0x68 0x69 0x6A 0x6B 0x6C 0x6D 0x6E 0x6F
0x70 0x71 0x72 0x73 0x74 0x75 0x76 0x77 0x78 0x79 0x7A 0x7B 0x7C 0x7D 0x7E 0x7F
0x80 0x81 0x82 0x83 0x84 0x85 0x86 0x87 0x88 0x89 0x8A 0x8B 0x8C 0x8D 0x8E 0x8F
0x90 0x91 0x92 0x93 0x94 0x95 0x96 0x97 0x98 0x99 0x9A 0x9B 0x9C 0x9D 0x9E 0x9F
0xA0 0xA1 0xA2 0xA3 0xA4 0xA5 0xA6 0xA7 0xA8 0xA9 0xAA 0xAB 0xAC 0xAD 0xAE 0xAF
0xB0 0xB1 0xB2 0xB3 0xB4 0xB5 0xB6 0xB7 0xB8 0xB9 0xBA 0xBB 0xBC 0xBD 0xBE 0xBF
0xC0 0xC1 0xC2 0xC3 0xC4 0xC5 0xC6 0xC7 0xC8 0xC9 0xCA 0xCB 0xCC 0xCD 0xCE 0xCF
0xD0 0xD1 0xD2 0xD3 0xD4 0xD5 0xD6 0xD7 0xD8 0xD9 0xDA 0xDB 0xDC 0xDD 0xDE 0xDF
0xE0 0xE1 0xE2 0xE3 0xE4 0xE5 0xE6 0xE7 0xE8 0xE9 0xEA 0xEB 0xEC 0xED 0xEE 0xEF
0xF0 0xF1 0xF2 0xF3 0xF4 0xF5 0xF6 0xF7 0xF8 0xF9 0xFA 0xFB 0xFC 0xFD 0xFE 0xFF
AT24C02 reading...
0x00 0x01 0x02 0x03 0x04 0x05 0x06 0x07 0x08 0x09 0x0A 0x0B 0x0C 0x0D 0x0E 0x0F
0x10 0x11 0x12 0x13 0x14 0x15 0x16 0x17 0x18 0x19 0x1A 0x1B 0x1C 0x1D 0x1E 0x1F
0x20 0x21 0x22 0x23 0x24 0x25 0x26 0x27 0x28 0x29 0x2A 0x2B 0x2C 0x2D 0x2E 0x2F
0x30 0x31 0x32 0x33 0x34 0x35 0x36 0x37 0x38 0x39 0x3A 0x3B 0x3C 0x3D 0x3E 0x3F
0x40 0x41 0x42 0x43 0x44 0x45 0x46 0x47 0x48 0x49 0x4A 0x4B 0x4C 0x4D 0x4E 0x4F
0x50 0x51 0x52 0x53 0x54 0x55 0x56 0x57 0x58 0x59 0x5A 0x5B 0x5C 0x5D 0x5E 0x5F
0x60 0x61 0x62 0x63 0x64 0x65 0x66 0x67 0x68 0x69 0x6A 0x6B 0x6C 0x6D 0x6E 0x6F
0x70 0x71 0x72 0x73 0x74 0x75 0x76 0x77 0x78 0x79 0x7A 0x7B 0x7C 0x7D 0x7E 0x7F
0x80 0x81 0x82 0x83 0x84 0x85 0x86 0x87 0x88 0x89 0x8A 0x8B 0x8C 0x8D 0x8E 0x8F
0x90 0x91 0x92 0x93 0x94 0x95 0x96 0x97 0x98 0x99 0x9A 0x9B 0x9C 0x9D 0x9E 0x9F
0xA0 0xA1 0xA2 0xA3 0xA4 0xA5 0xA6 0xA7 0xA8 0xA9 0xAA 0xAB 0xAC 0xAD 0xAE 0xAF
0xB0 0xB1 0xB2 0xB3 0xB4 0xB5 0xB6 0xB7 0xB8 0xB9 0xBA 0xBB 0xBC 0xBD 0xBE 0xBF
0xC0 0xC1 0xC2 0xC3 0xC4 0xC5 0xC6 0xC7 0xC8 0xC9 0xCA 0xCB 0xCC 0xCD 0xCE 0xCF
0xD0 0xD1 0xD2 0xD3 0xD4 0xD5 0xD6 0xD7 0xD8 0xD9 0xDA 0xDB 0xDC 0xDD 0xDE 0xDF
0xE0 0xE1 0xE2 0xE3 0xE4 0xE5 0xE6 0xE7 0xE8 0xE9 0xEA 0xEB 0xEC 0xED 0xEE 0xEF
0xF0 0xF1 0xF2 0xF3 0xF4 0xF5 0xF6 0xF7 0xF8 0xF9 0xFA 0xFB 0xFC 0xFD 0xFE 0xFF
I2C-AT24C02 test passed!
```

## 5.12 SPI\_SPI\_Flash

### 5.12.1 DEMO Purpose

This demo includes the following functions of GD32 MCU:

- Learn to use the master mode of SPI unit to read and write NOR Flash with the SPI interface

### 5.12.2 DEMO Running Result

The computer serial port line connected to the COM1 port of development board, set the baud rate of HyperTerminal software to 115200, 8 bits data bit, 1 bit stop bit. At the same time you should jump the JP5 and JP6 to USART, and jump the JP12 to SPI.

Download the program <12\_SPI\_SPI\_Flash> to the EVAL board, the HyperTerminal software can observe the operation condition and will display the ID of the flash, 256 bytes data which are written to and read from flash. Compare the data that were written to the flash and the data that were read from the flash. If they are the same, the serial port will output "SPI-GD25Q40 Test Passed!", otherwise, the serial port will output "Err: Data Read and Write aren't Matching.". At last, turn on and off the leds one by one. The following is the experimental results.



```
#####
GD32403Z-EVAL-V1.0 System is Starting up...
GD32403Z-EVAL-V1.0 Flash:512K
GD32403Z-EVAL-V1.0 The CPU Unique Device ID: [37373431-7363533-600200]
GD32403Z-EVAL-V1.0 SPI Flash:GD25Q16 configured...
The Flash_ID:0xC84015

Write to tx_buffer:
0x00 0x01 0x02 0x03 0x04 0x05 0x06 0x07 0x08 0x09 0x0A 0x0B 0x0C 0x0D 0x0E 0x0F
0x10 0x11 0x12 0x13 0x14 0x15 0x16 0x17 0x18 0x19 0x1A 0x1B 0x1C 0x1D 0x1E 0x1F
0x20 0x21 0x22 0x23 0x24 0x25 0x26 0x27 0x28 0x29 0x2A 0x2B 0x2C 0x2D 0x2E 0x2F
0x30 0x31 0x32 0x33 0x34 0x35 0x36 0x37 0x38 0x39 0x3A 0x3B 0x3C 0x3D 0x3E 0x3F
0x40 0x41 0x42 0x43 0x44 0x45 0x46 0x47 0x48 0x49 0x4A 0x4B 0x4C 0x4D 0x4E 0x4F
0x50 0x51 0x52 0x53 0x54 0x55 0x56 0x57 0x58 0x59 0x5A 0x5B 0x5C 0x5D 0x5E 0x5F
0x60 0x61 0x62 0x63 0x64 0x65 0x66 0x67 0x68 0x69 0x6A 0x6B 0x6C 0x6D 0x6E 0x6F
0x70 0x71 0x72 0x73 0x74 0x75 0x76 0x77 0x78 0x79 0x7A 0x7B 0x7C 0x7D 0x7E 0x7F
0x80 0x81 0x82 0x83 0x84 0x85 0x86 0x87 0x88 0x89 0x8A 0x8B 0x8C 0x8D 0x8E 0x8F
0x90 0x91 0x92 0x93 0x94 0x95 0x96 0x97 0x98 0x99 0x9A 0x9B 0x9C 0x9D 0x9E 0x9F
0xA0 0xA1 0xA2 0xA3 0xA4 0xA5 0xA6 0xA7 0xA8 0xA9 0xAA 0xAB 0xAC 0xAD 0xAE 0xAF
0xB0 0xB1 0xB2 0xB3 0xB4 0xB5 0xB6 0xB7 0xB8 0xB9 0xBA 0xBB 0xBC 0xBD 0xBE 0xBF
0xC0 0xC1 0xC2 0xC3 0xC4 0xC5 0xC6 0xC7 0xC8 0xC9 0xCA 0xCB 0xCC 0xCD 0xCE 0xCF
0xD0 0xD1 0xD2 0xD3 0xD4 0xD5 0xD6 0xD7 0xD8 0xD9 0xDA 0xDB 0xDC 0xDD 0xDE 0xDF
0xE0 0xE1 0xE2 0xE3 0xE4 0xE5 0xE6 0xE7 0xE8 0xE9 0xEA 0xEB 0xEC 0xED 0xEE 0xEF
0xF0 0xF1 0xF2 0xF3 0xF4 0xF5 0xF6 0xF7 0xF8 0xF9 0xFA 0xFB 0xFC 0xFD 0xFE 0xFF

Read from rx_buffer:0x00 0x01 0x02 0x03 0x04 0x05 0x06 0x07 0x08 0x09 0x0A 0x0B
0x0C 0x0D 0x0E 0x0F 0x10 0x11 0x12 0x13 0x14 0x15 0x16 0x17 0x18 0x19 0x1A 0x1B
0x1C 0x1D 0x1E 0x1F 0x20 0x21 0x22 0x23 0x24 0x25 0x26 0x27 0x28 0x29 0x2A 0x2B
0x2C 0x2D 0x2E 0x2F 0x30 0x31 0x32 0x33 0x34 0x35 0x36 0x37 0x38 0x39 0x3A 0x3B
0x3C 0x3D 0x3E 0x3F 0x40 0x41 0x42 0x43 0x44 0x45 0x46 0x47 0x48 0x49 0x4A 0x4B
0x4C 0x4D 0x4E 0x4F 0x50 0x51 0x52 0x53 0x54 0x55 0x56 0x57 0x58 0x59 0x5A 0x5B
0x5C 0x5D 0x5E 0x5F 0x60 0x61 0x62 0x63 0x64 0x65 0x66 0x67 0x68 0x69 0x6A 0x6B
0x6C 0x6D 0x6E 0x6F 0x70 0x71 0x72 0x73 0x74 0x75 0x76 0x77 0x78 0x79 0x7A 0x7B
0x7C 0x7D 0x7E 0x7F 0x80 0x81 0x82 0x83 0x84 0x85 0x86 0x87 0x88 0x89 0x8A 0x8B
0x8C 0x8D 0x8E 0x8F 0x90 0x91 0x92 0x93 0x94 0x95 0x96 0x97 0x98 0x99 0x9A 0x9B
0x9C 0x9D 0x9E 0x9F 0xA0 0xA1 0xA2 0xA3 0xA4 0xA5 0xA6 0xA7 0xA8 0xA9 0xAA 0xAB
0xAC 0xAD 0xAE 0xAF 0xB0 0xB1 0xB2 0xB3 0xB4 0xB5 0xB6 0xB7 0xB8 0xB9 0xBA 0xBB
0xBC 0xBD 0xBE 0xBF 0xC0 0xC1 0xC2 0xC3 0xC4 0xC5 0xC6 0xC7 0xC8 0xC9 0xCA 0xCB
0xCC 0xCD 0xCE 0xCF 0xD0 0xD1 0xD2 0xD3 0xD4 0xD5 0xD6 0xD7 0xD8 0xD9 0xDA 0xDB
0xDC 0xDD 0xDE 0xDF 0xE0 0xE1 0xE2 0xE3 0xE4 0xE5 0xE6 0xE7 0xE8 0xE9 0xEA 0xEB
0xEC 0xED 0xEE 0xEF 0xF0 0xF1 0xF2 0xF3 0xF4 0xF5 0xF6 0xF7 0xF8 0xF9 0xFA 0xFB
0xFC 0xFD 0xFE 0xFF
SPI-GD25Q16 Test Passed!
```

## 5.13 I2S\_Audio\_Player

### 5.13.1 DEMO Purpose

This Demo includes the following functions of GD32 MCU:

- Learn to use I2S module to output audio file
- Parsing audio files of wav format

GD32403Z-EVAL board integrates the I2S (Inter-IC Sound) module, and the module can communicate with external devices using the I2S audio protocol. This Demo mainly shows how to use the I2S interface of the board for audio output.

## 5.13.2 DEMO Running Result

Download the program<13\_I2S\_Audio\_Player>to the EVAL board, insert the headphone into the audio port, and then listen to the audio file.

## 5.14 EXMC\_NandFlash

### 5.14.1 DEMO Purpose

This demo includes the following functions of GD32 MCU:

- Learn to use EXMC control the NAND flash

### 5.14.2 DEMO Running Result

GD32403Z-EVAL board has EXMC module to control NAND flash. Before running the demo, JP5 and JP6 must be fitted to USART, P2 and P3 must be fitted to the EXMC port, JP24 must be fitted to the Nwait port. Download the program <14\_EXMC\_NandFlash> to the EVAL board. This demo shows the write and read operation process of NAND flash memory by EXMC module. If the test pass, LED2 will be turned on. Otherwise, turn on the LED4. Information via a HyperTerminal output as following:

```
NAND flash initialized!
Read NAND ID!
Nand flash ID:0xAD 0xF1 0x80 0x1D

Write data successfully!
Read data successfully!
Check the data!
Access NAND flash successfully!
The data to be read:
0x00 0x01 0x02 0x03 0x04 0x05 0x06 0x07 0x08 0x09 0x0A 0x0B 0x0C 0x0D 0x0E 0x0F
0x10 0x11 0x12 0x13 0x14 0x15 0x16 0x17 0x18 0x19 0x1A 0x1B 0x1C 0x1D 0x1E 0x1F
0x20 0x21 0x22 0x23 0x24 0x25 0x26 0x27 0x28 0x29 0x2A 0x2B 0x2C 0x2D 0x2E 0x2F
0x30 0x31 0x32 0x33 0x34 0x35 0x36 0x37 0x38 0x39 0x3A 0x3B 0x3C 0x3D 0x3E 0x3F
0x40 0x41 0x42 0x43 0x44 0x45 0x46 0x47 0x48 0x49 0x4A 0x4B 0x4C 0x4D 0x4E 0x4F
0x50 0x51 0x52 0x53 0x54 0x55 0x56 0x57 0x58 0x59 0x5A 0x5B 0x5C 0x5D 0x5E 0x5F
0x60 0x61 0x62 0x63 0x64 0x65 0x66 0x67 0x68 0x69 0x6A 0x6B 0x6C 0x6D 0x6E 0x6F
0x70 0x71 0x72 0x73 0x74 0x75 0x76 0x77 0x78 0x79 0x7A 0x7B 0x7C 0x7D 0x7E 0x7F
0x80 0x81 0x82 0x83 0x84 0x85 0x86 0x87 0x88 0x89 0x8A 0x8B 0x8C 0x8D 0x8E 0x8F
0x90 0x91 0x92 0x93 0x94 0x95 0x96 0x97 0x98 0x99 0x9A 0x9B 0x9C 0x9D 0x9E 0x9F
0xA0 0xA1 0xA2 0xA3 0xA4 0xA5 0xA6 0xA7 0xA8 0xA9 0xAA 0xAB 0xAC 0xAD 0xAE 0xAF
0xB0 0xB1 0xB2 0xB3 0xB4 0xB5 0xB6 0xB7 0xB8 0xB9 0xBA 0xBB 0xBC 0xBD 0xBE 0xBF
0xC0 0xC1 0xC2 0xC3 0xC4 0xC5 0xC6 0xC7 0xC8 0xC9 0xCA 0xCB 0xCC 0xCD 0xCE 0xCF
0xD0 0xD1 0xD2 0xD3 0xD4 0xD5 0xD6 0xD7 0xD8 0xD9 0xDA 0xDB 0xDC 0xDD 0xDE 0xDF
0xE0 0xE1 0xE2 0xE3 0xE4 0xE5 0xE6 0xE7 0xE8 0xE9 0xEA 0xEB 0xEC 0xED 0xEE 0xEF
0xF0 0xF1 0xF2 0xF3 0xF4 0xF5 0xF6 0xF7 0xF8 0xF9 0xFA 0xFB 0xFC 0xFD 0xFE 0xFF
0x00 0x01 0x02 0x03 0x04 0x05 0x06 0x07 0x08 0x09 0x0A 0x0B 0x0C 0x0D 0x0E 0x0F
```

## 5.15 EXMC\_TouchScreen

### 5.15.1 DEMO Purpose

This demo includes the following functions of GD32 MCU:

- Learn to use EXMC control LCD

### 5.15.2 DEMO Running Result

GD32403Z-EVAL board has EXMC module to control LCD. Before running the demo, JP12 must be fitted to the SPI port, P2 and P3 must be fitted to the EXMC port. Download the program <15\_EXMC\_TouchScreen> to the EVAL board. This demo displays GigaDevice logo and four green buttons on the LCD screen by EXMC module. Users can touch the green button to turn on the corresponding LED on board, and then the color of button you had touched will change to red.



## 5.16 SDIO\_SDCardTest

### 5.16.1 DEMO Purpose

This demo includes the following functions of GD32 MCU:

- Learn to use SDIO to single block or multiple block write and read
- Learn to use SDIO to erase, lock and unlock a SD card

GD32403Z-EVAL board has a secure digital input/output interface (SDIO) which defines the SD/SD I/O /MMC CE-ATA card host interface. This demo will show how to use SDIO to operate on SD card.

### 5.16.2 DEMO Running Result

Jump the JP5 to USART to show the print message through HyperTerminal, and download the program <16\_SDIO\_SDCardTest> to the EVAL board and run. Connect serial cable to EVAL\_COM1, open the HyperTerminal. Firstly, all the LEDs flash once for test. Then initialize the card and print out the information of the card. After that, test the function of single block operation, lock and unlock operation, erase operation and multiple blocks operation. If any error occurs, print the error message and turn on LED2, LED4 and turn off LED3 and LED5. Otherwise, turn on all the LEDs.

Uncomment the macro DATA\_PRINT to print out the data and display them through HyperTerminal. Set bus mode(1-bit or 4-bit) and data transfer mode(polling mode or DMA mode) by comment and uncomment the related statements.

Information via a serial port output as following.

```
Card init success!

Card information:
## Card version 3.0x ##
## SDHC card ##
## Device size is 7782400KB ##
## Block size is 512B ##
## Block count is 15564800 ##
## CardCommandClasses is: 5b5 ##
## Block operation supported ##
## Erase supported ##
## Lock unlock supported ##
## Application specific supported ##
## Switch function supported ##

Card test:
Block write success!
Block read success!
The card is locked!
Erase failed!
The card is unlocked!
Erase success!
Block read success!
Multiple block write success!
Multiple block read success!
```

## 5.17 CAN\_Network

### 5.17.1 DEMO Purpose

This demo includes the following functions of GD32 MCU:

- Learn to use the CAN0 communication between two boards

GD32403Z-EVAL development board integrates the CAN(Controller Area Network) bus controller, which is a common industrial control bus. CAN bus controller follows the CAN bus protocol of 2.0 A and 2.0 B. This demo mainly shows how to communicate two EVAL boards through CAN0.

### 5.17.2 DEMO Running Result

This example is tested with two GD32F403Z-EVAL boards. Jump the JP5 and JP6 to USART and P2, P3 to CAN with the jumper cap. Connect L pin to L pin and H pin to H pin of JP14 on the boards for sending and receiving frames. Download the program <17\_CAN\_Network> to the two EVAL boards, and connect serial cable to EVAL\_COM1. Firstly, the EVAL\_COM1 sends “please press the Tamper key to transmit data!” to the HyperTerminal. The frames are sent and the transmit data are printed by pressing Tamper Key push button. When the frames are received, the receive data will be printed and the LED2 will toggle one time.

The output information via the serial port is as following.

```
please press the Tamper key to transmit data!  
CAN0 transmit data: ab,cd  
CAN0 receive data: ab,cd
```

## 5.18 RCU\_Clock\_Out

### 5.18.1 DEMO Purpose

This demo includes the following functions of GD32 MCU:

- Learn to use GPIO control the LED
- Learn to use the clock output function of RCU
- Learn to communicate with PC by USART

## 5.18.2 DEMO Running Result

Jump the JP5 and JP6 to USART with the jumper cap, and download the program <18\_RCU\_Clock\_Out> to the EVAL board and run. Connect serial cable to EVAL\_COM1, open the HyperTerminal. When the program is running, HyperTerminal will display the initial information. Then user can choose the type of the output clock by pressing the TAMPER button. After pressing, the corresponding LED will be turned on and HyperTerminal will display which mode be selected. The frequency of the output clock can be observed through the oscilloscope by PA8 pin.

Information via a serial port output as following:

```
/===== Gigadevice Clock output Demo =====/  
press tamper key to select clock output source  
CK_OUT0: system clock  
CK_OUT0: IRC8M  
CK_OUT0: HXTAL  
CK_OUT0: system clock
```

## 5.19 CTC\_Calibration

### 5.19.1 DEMO Purpose

This demo includes the following functions of GD32 MCU:

- Learn to use external low speed crystal oscillator (LXTAL) to implement the CTC calibration function
- Learn to use clock trim controller (CTC) to trim internal 48MHz RC oscillator (IRC48M) clock

The CTC unit trim the frequency of the IRC48M based on an external accurate reference signal source. It can automatically adjust the trim value to provide a precise IRC48M clock.

### 5.19.2 DEMO Running Result

Download the program <19\_CTC\_Calibration> to the EVAL board and run. Firstly, all the LEDs flash once for test. Then if the clock trim is OK, LED2 will be on. Otherwise, all the LEDs are turned off.

## 5.20 PMU\_sleep\_wakeup

### 5.20.1 DEMO Purpose

This demo includes the following functions of GD32 MCU:

- Learn to use the USART receive interrupt to wake up the PMU from sleep mode

### 5.20.2 DEMO Running Result

Download the program < 20\_PMU\_sleep\_wakeup > to the EVAL board, jump the JP5 and JP6 to USART with the jumper cap and connect serial cable to EVAL\_COM1. After power-on, all the LEDs are off. The mcu will enter sleep mode and the software stop running. When the USART0 receives a byte of data from the HyperTerminal, the mcu will wake up from a receive interrupt. And all the LEDs will flash together.

## 5.21 RTC\_Calendar

### 5.21.1 DEMO Purpose

This demo includes the following functions of GD32 MCU:

- Learn to use RTC module to implement calendar and alarm function
- Learn to use USART module to implement time display

### 5.21.2 DEMO Running Result

Jump the JP5 and JP6 to USART with the jumper cap, and download the program <21\_RTC\_Calendar> to the EVAL board and run. Connect serial cable to EVAL\_COM1, open the HyperTerminal. After start-up, the program will ask to set the time on the HyperTerminal. The calendar will be displayed on the HyperTerminal. At the same time, set current time add 10 second as alarm time. After 10 second, the alarm note will displayed on the HyperTerminal and turn on LEDs.



```
=====Time Settings=====
Please Set Hours: 23
Please Set Minutes: 23
Please Set Seconds: 23
Set Alarm Time: 23:23:33

Time: 23:23:23
Time: 23:23:23
Time: 23:23:24
Time: 23:23:25
Time: 23:23:26
Time: 23:23:27
Time: 23:23:28
Time: 23:23:29
Time: 23:23:30
Time: 23:23:31
Time: 23:23:32

=====RTC Alarm and turn on LED=====
Time: 23:23:33
```

## 5.22 TIMER\_Breath\_LED

### 5.22.1 DEMO Purpose

This demo includes the following functions of GD32 MCU:

- Learn to use Timer output PWM wave
- Learn to update channel value

### 5.22.2 DEMO Running Result

Use the DuPont line to connect the TIMER0\_CH0 (PA8) and LED2 (PF0), and then download the program <22\_TIMER\_Breath\_LED> to the GD32403Z-EVAL board and run. PA8 should not be reused by other peripherals.

When the program is running, you can see LED2 lighting from dark to bright gradually and then gradually darken, ad infinitum, just like breathing as rhythm.

## 5.23 USB\_Device

### 5.23.1 HID\_Keyboard

#### DEMO Purpose

This demo includes the following functions of GD32 MCU:

- Learn how to use the USBFS peripheral mode
- Learn how to implement USB HID(human interface) device

GD32403Z-EVAL board has five keys and one USB\_FS interface. The five keys are



Reset key, Wakeup key, Tamper key, User key1 and User key2. In this demo, the GD32403Z-EVAL board is enumerated as an USB Keyboard, which uses the native PC Host HID driver, as shown below. The USB Keyboard uses three keys(wakeup key, tamper key and user key1) to output three characters ('b', 'a' and 'c'). In addition, the demo also supports remote wakeup which is the ability of a USB device to bring a suspended bus back to the active condition, and the wakeup key is used as the remote wakeup source.



## DEMO Running Result

Before running the demo, please ensure that jumper JP5, JP6 jump to OTG. After doing this, download the program <23\_USBFS\USB\_Device\HID\_Keyboard> to the EVAL board and run. If you press the Wakeup key, will output 'b'. If you press the User key, will output 'c'. If you press the Tamper key, will output 'a'.

If you want to test USB remote wakeup function, you can do as follows:

- Manually switch PC to standby mode
- Wait for PC to fully enter the standby mode
- Push the Wakeup key
- If PC is ON, remote wakeup is OK, else failed.

### 5.23.2 MSC\_Udisk

#### DEMO Purpose

This demo includes the following functions of GD32 MCU:

- Learn how to use the USB\_FS peripheral mode
- Learn how to implement USB MSC(mass storage) device

This demo mainly implements a U disk. U disk is currently very widely used removable MSC devices. MSC, the Mass Storage device Class, is a transport protocol between a computer and mobile devices, which allow a universal serial bus (USB) equipment to access a host computing device, file transfer between them, mainly including mobile hard disk, mobile U disk drive, etc... The MSC device must have a storage medium, and this Demo uses the MCU's internal SRAM as the storage medium. For more details of the

MSC protocol please refer to the MSC protocol standard.

MSC device will use a variety of transport protocols and command formats for communication, so it need to choose the appropriate protocol and command format in the realization of the application. This Demo selects the BOT (bulk only transport) protocol and the required SCSI (small computer interface) command, and is compatible with a wide variety of Window operating systems. Specific BOT protocol and SCSI command specification please refer to the standard of their agreement.

## DEMO Running Result

Before running the demo, please ensure that jumper JP5, JP6 jump to OTG. After doing this, download the program <23\_USBFS\USB\_Device\MSC(Internal\_sram)> to the EVAL board and run. When the EV-board connect to the PC, you will find a USB large capacity storage device is in the universal serial bus controller, and there is 1 more disk drives in the equipment manager of PC, as shown below:

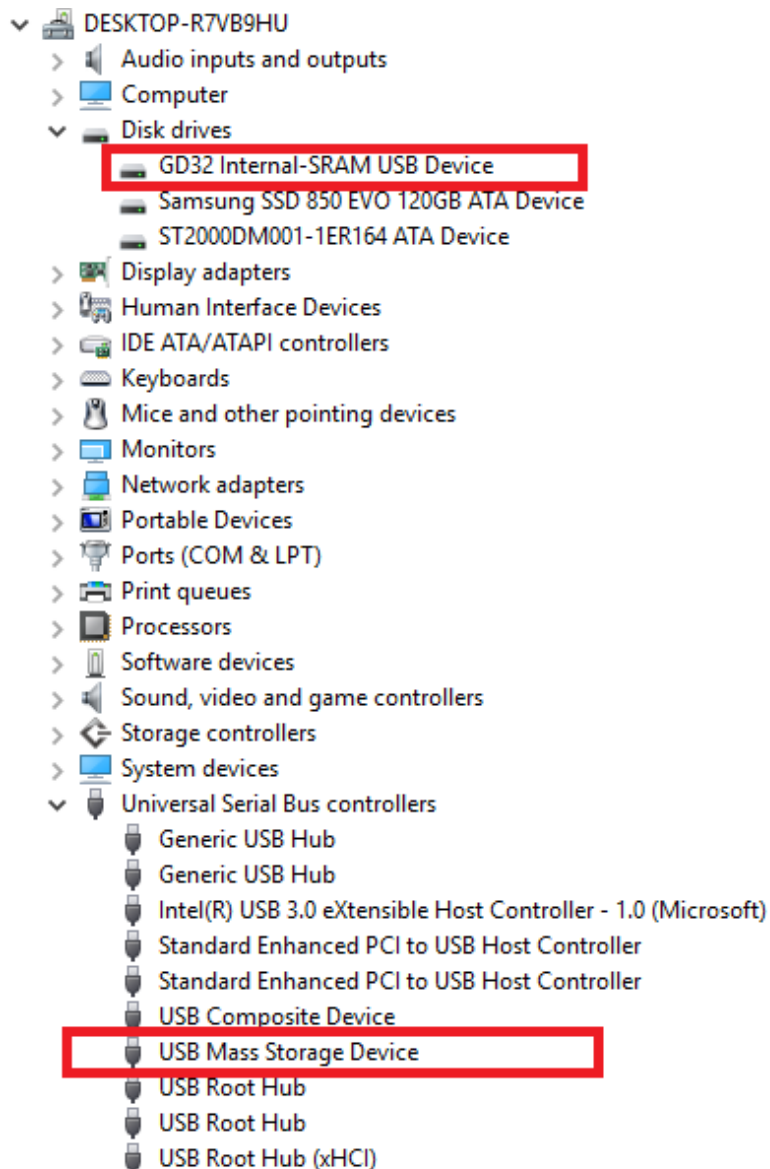

Then, after opening the resource manager, you will see more of the 1 disk, as shown in

the following diagram:

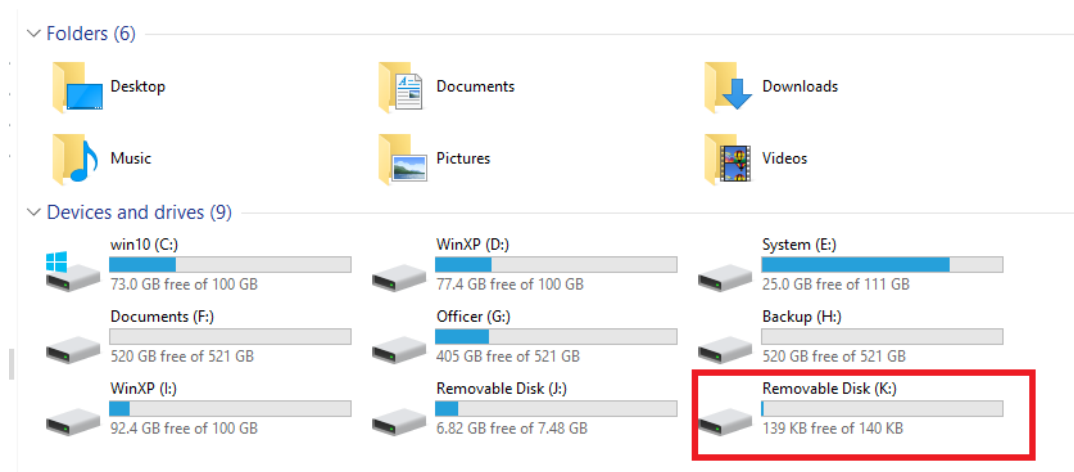

At this point, the write/read/formatting operation can be performed as the other mobile devices.

## 5.24 USB\_Host

### 5.24.1 HID\_Host

#### DEMO Purpose

This demo includes the following functions of GD32 MCU:

- Learn to use the USBFS as a HID host
- Learn the operation between the HID host and the mouse device
- Learn the operation between the HID host and the keyboard device

GD32403Z-EVAL board integrates the USBFS module, and the module can be used as a USB device, a USB host or an OTG device. This demo mainly shows how to use the USBFS as a USB HID host to communicate with external USB HID device.

#### DEMO Running Result

Jump the JP5 and the JP6 to OTG. Then download the program <23\_USBFS\USB\_Host\HID\_Host> to the EVAL board and run.

If a mouse has been attached, the user will see the information of mouse enumeration. First pressing the user key1 will see the inserted device is mouse, and then moving the mouse will show the position of mouse and the state of button in the screen.

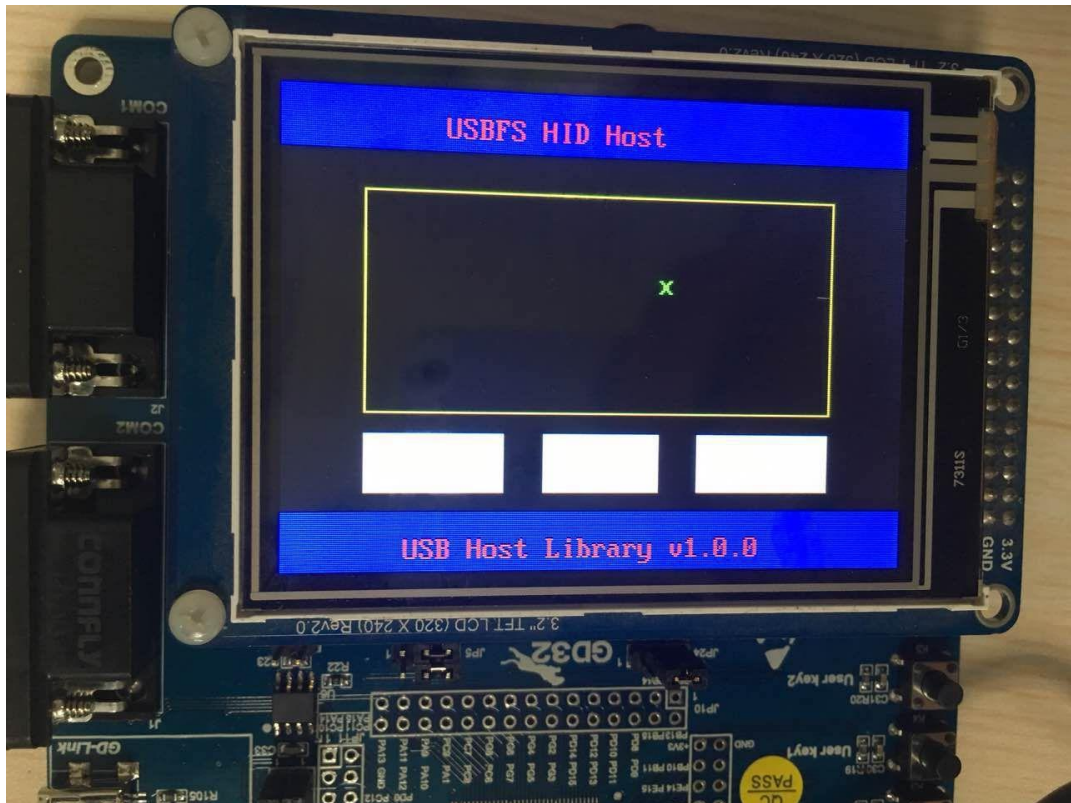

If a keyboard has been attached, the user will see the information of keyboard enumeration. First pressing the user key1 will see the inserted device is keyboard, and then pressing the keyboard will show the state of the button in the screen.



## 5.24.2 MSC\_Host

### DEMO Purpose

This demo includes the following functions of GD32 MCU:

- Learn to use the USBFS as a MSC host
- Learn the operation between the MSC host and the Udisk

GD32403Z-EVAL board integrates the USBFS module, and the module can be used as a USB device, a USB host or an OTG device. This demo mainly shows how to use the USBFS as a USB MSC host to communicate with external Udisk.

### DEMO Running Result

Jump the JP5 and the JP6 to OTG. Then insert the OTG cable to the USB port, download the program <23\_USBFS\USB\_Host\MSC\_Host > to the EVAL board and run.

If an Udisk has been attached, the user will see the information of Udisk enumeration. First pressing the user key1 will see the Udisk information, next pressing the tamper key will see the root content of the Udisk, then press the wakeup key will write file to the Udisk, finally the user will see information that the msc host demo is end.

## 6 Revision history

Table 2 Revision history

Revision No.	Description	Date
1.0	Initial Release	May. 19, 2017